

Model OTPN-3850-SA 3.85GHz Wideband FTTH PON Receiver

Features / Benefits

Wide bandwidth FTTH PON receiver incorporates a WDM to pass 1310nm and 1490nm and to detect 1550nm over a bandwidth of 50-3,850 MHz.

Receive only indoor optical node for fiber-deep FTTH/PON CATV applications.

Wide operating optical input window of 0 to -6dBm at 1550nm.

CATV parameters are optimized at -4dBm optical input.

CATV RF output: +23dBmV typical per channel at 3% OMI per channel over rated optical input window.

Full forward path bandwidth of 50-3,850MHz with low noise and distortion accommodates full band CATV and multiple satellites.

Compatible with most external frequency destackers. An external destacker is required to recover stacked satellite signals.

Green LED for positive indication of power.

Red LED for optical input loss (signal level below -10dBm).

Open collector alarm for optical input loss (when signal level drops below -10dBm).

+12 to +16 V_{DC} power.



The Olson Technology, Inc. **Model OTPN-3850-SA** provides 50-3,850 MHz bandwidth, allowing it to carry CATV signals from 50-870 MHz along with two stacked 950-2,150MHz L-Band signals. The L-Band signals are usually at a level below the CATV signals.

The optical input contains downstream forward path CATV and L-Band signals at 1550nm, downstream Ethernet data at 1490nm and upstream Ethernet data at 1310nm. The optical output passes the 1310nm and 1490nm signals. The 1550nm wavelength goes to a photodiode and is amplified. The optical input level is sensed to trigger an optical alarm if the input light level is below -10dBm. The input optical level is also used to control a PIN diode attenuator maintaining constant RF level as the optical input level varies from 0dBm to -6dBm. The signal is then amplified and output to a single "F" connector output.

The OTPN-3850-SA Integrated PON Receiver dimensions are 1.05" H x 3.15" W x 4.75" L. Optical connections are via SC/APC connectors, one for the optical input carrying 1310nm, 1490nm & 1550nm, the second for the optical output carrying the 1310nm and 1490nm optical signals. The unit is powered from +12 to +16 Volts DC at 0.2A maximum. A Green Power LED is lit whenever valid supply voltage is applied. A Red LED is lit only when the optical power drops below -10dBm, the minimum usable optical input level. The right side of the unit has a single "F" connector providing a 50-3,850MHz signal.

Optical Characteristics
(with SM 9/125µm SM Fiber)

	Min	Typ	Max	Units
Operating Wavelength (Rx)	1540	1550	1560	nm
Passband λ Range 1	1280	1310	1340	nm
Passband λ Range 2	1480	1490	1500	nm
Insertion Loss - λ Range 1		0.45	0.60	dB
Insertion Loss - λ Range 2		0.35	0.60	dB
Isolation - λ Range 1 to PD	40			dB
Isolation - λ Range 2 to PD	40			dB
Isolation - CATV to Output	15	45		dB
Optical Input Power - CATV	-6		0	dBm
Optical Return Loss	-40	-55		dB
Optical LOS LED (Red)	-11	-10	-9	dBm
Optical Connector (Std.)	SC/APC			

RF Output & Performance Characteristics

	Min	Typ	Max	Units
Frequency Range	50		3,850	MHz
Band Flatness (50-870MHz)	-1.5		+1.5	dB
(950-3,850MHz)	-2.5		+2.5	dB
(Any 20MHz)	-0.5		+0.5	dB
CATV RF Level (@ -4dBm) ⁽¹⁾		+23		dBmV
Optical AGC Range ⁽²⁾	-6		0	dBm
Impedance (F Connector)		75		Ohms
CATV Output Freq. Response	50		870	MHz
CNR (@ -4dBm Opt. In)	47			dB
CSO (@ -4dBm Opt. In)			-55	dBc
CTB (@ -4dBm Opt. In)			-55	dBc

(1) At 3% OMI per channel.
(2) RF Output Level varies no more than ±2dB over this optical range.

Electrical & Environmental Characteristics

	Min	Typ	Max	Units
Power Supply Voltage	+12		+16	V _{DC}
Operating Current		0.25	0.35	A
Operating Temp. Range	-40		+65	°C
Humidity (RH Non-condensing)	10		90	%

Physical Characteristics

	Min	Typ	Max	Units
Weight		6.3		oz.
		179		g
Dimensions (H x W x L)	1.05 x 3.15* x 4.75			in.
	2.67 x 8.0* x 12.1			cm

* Width of mounting flange is 4.05" (10.3cm)

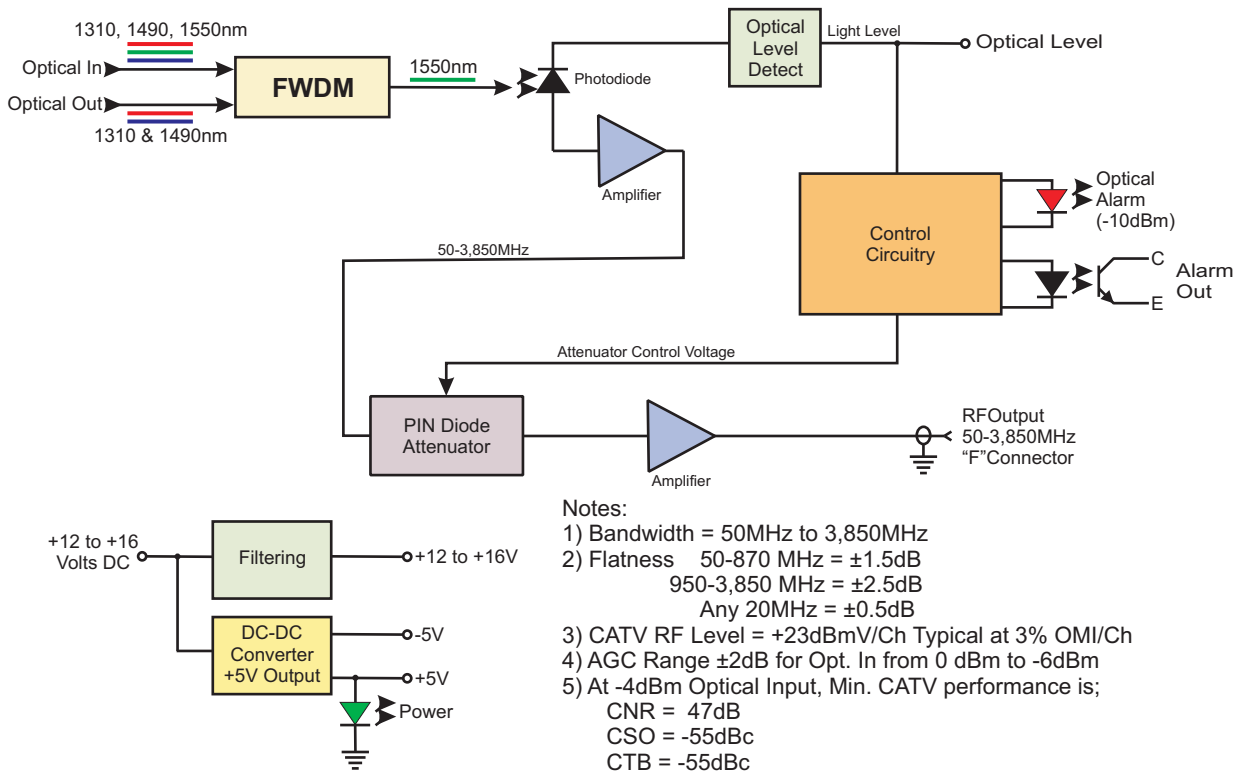

Notes:

- 1) Bandwidth = 50MHz to 3,850MHz
- 2) Flatness 50-870 MHz = ±1.5dB
950-3,850 MHz = ±2.5dB
Any 20MHz = ±0.5dB
- 3) CATV RF Level = +23dBmV/Ch Typical at 3% OMI/Ch
- 4) AGC Range ±2dB for Opt. In from 0 dBm to -6dBm
- 5) At -4dBm Optical Input, Min. CATV performance is:
CNR = 47dB
CSO = -55dBc
CTB = -55dBc
- 6) Loss of Light Threshold = -10dBm ±1dB (1550nm power only)

Ordering Information

Model OTPN-3850-SA PON Receiver (50-3,850 MHz), Receive Only, +23dBmV @ -4dBm, SC/APC Optical Connector