



OTOT-1000C & OTOT-1000E

**WIDE-BAND LOW-COST OPTICAL TRANSMITTERS
1,000MHz BANDWIDTH
OPTICAL OUTPUT POWER FROM
+3dBm (OTOT-1000C-3) to +15dBm (OTOT-1000C-15)**

INSTRUCTION MANUAL



Phone: (209) 586-1022
(800) 545-1022

Fax: (209) 586-1026

E-Mail: salesupport@olsontech.com
www.olsontech.com

SAFETY WARNINGS



LASER RADIATION



The OTOT-1000C laser transmitter emits invisible radiation that can cause permanent eye damage. ***AVOID DIRECT EXPOSURE TO BEAM.*** Operate the transmitter only with the proper optical fiber installed in the transmitter optical connector. The OTOT-1000C should be turned-off or disconnected whenever the optical connector cover is opened and there is no installed fiber (as when the fiber connector is being installed or removed from the transmitter connector).

NEVER USE ANY OPTICAL INSTRUMENT TO VIEW THE OUTPUT OF THE LASER TRANSMITTER. "OPTICAL INSTRUMENT" INCLUDES MAGNIFYING GLASSES, ETC.

NEVER LOOK INTO THE OUTPUT OF THE LASER TRANSMITTER

NEVER LOOK INTO THE OUTPUT OF A FIBER CONNECTED TO A LASER TRANSMITTER.

NEVER LOOK INTO OR USE ANY OPTICAL INSTRUMENT TO VIEW THE DISTANT END OF A FIBER THAT MAY BE CONNECTED DIRECTLY OR VIA AN OPTICAL SPLIT, TO A TRANSMITTER THAT MAY BE OPERATING. THIS SPECIFICALLY APPLIES TO FIBERS THAT ARE TO BE CONNECTED TO RECEIVERS (SUCH AS THE OTPN-400C or OTPN-2000C) OR OTHER DEVICES AT ANY DISTANCE FROM THE LASER TRANSMITTER.

HIGH VOLTAGE - The inside of the OTOT-1000C contains no user serviceable parts. There is exposed high voltage inside this unit. Only factory service technicians should open the unit with power applied.

FIRE HAZARD - The AC line input fuse is contained in the IEC 320 power input connector. This fuse is a 250V, 0.5A, 5x20mm, slow blow fuse. To avoid a risk of fire, this fuse should be replaced only with an identically rated fuse.

SHOCK HAZARD - The OTOT-1000C is designed for indoor use only. Direct exposure to moisture must be avoided.

INTRODUCTION

The Olson Technology OTOT-1000C is a high performance indoor wideband laser transmitter with an RF passband of 48 to 1,000MHz. The OTOT-1000C also offers enhanced CATV performance. These transmitters are intended for indoor applications. They combine the transmitter and universal AC power supply in one compact housing that has a footprint of 6.5" x 5.5" x 1.4". The optical output power and bandwidth of each transmitter is as follows:

| | |
|---------------|------------------------------------|
| OTOT-1000C-3 | +3dBm (2mW) Optical Output Power |
| OTOT-1000C-6 | +6dBm (4mW) Optical Output Power |
| OTOT-1000C-8 | +8dBm (6mW) Optical Output Power |
| OTOT-1000C-9 | +9dBm (8mW) Optical Output Power |
| OTOT-1000C-10 | +10dBm (10mW) Optical Output Power |
| OTOT-1000C-12 | +12dBm (16mW) Optical Output Power |
| OTOT-1000C-13 | +13dBm (20mW) Optical Output Power |
| OTOT-1000C-14 | +14dBm (25mW) Optical Output Power |
| OTOT-1000C-15 | +15dBm (31mW) Optical Output Power |

The transmitter has an internal universal power supply that operates from 90 to 240V_{AC} at 50 or 60 Hz and consumes about 10 Watts.

The OTOT-1000C is an ideal forward signal source for the OTPN-2000C High Sensitivity Indoor Node and will allow for an optical path loss of 21dB or more. Test points are provided for laser output power and current to allow for historical review of operating parameters. An RF test point is provided to allow proper setup and for historical review. Positive cooling is provided by means of a small, high-MTBF fan, which may be replaced in the field without interrupting the operation of the unit. The OTOT-1000C has flanges on the bottom to allow mounting it to a flat surface. The available OTLL-RMKIT-1 will allow mounting up to three of these units in a standard 19" rack.

INSTALLATION / ENVIRONMENTAL CONSIDERATIONS

The OTOT-1000C transmitters are specified to operate from -10°C to +55°C. They usually do not require an air-conditioned environment. They should be mounted in an adequately ventilated area. Like all electronic equipment, it will generally have a longer life span if it is not operated at the upper limit of the temperature range. Installation in wet areas or areas of extremely high humidity should be avoided. Extremely dirty or dusty

areas should be avoided if possible. Objects or debris should not be allowed to block the openings in the housing or the fan. The unit should not be installed in areas that are accessible to children.

The OTOT-1000C may be installed and operated in any position on a flat surface. The unit has four slots in the bottom plate to accommodate mounting hardware. If mounting requires a wood screw, use #6 or #8 (maximum) pan-head sheet metal screws. These are commonly available at hardware stores. If mounting with a machine screw (to tapped holes), use 6-32 pan-head screws.

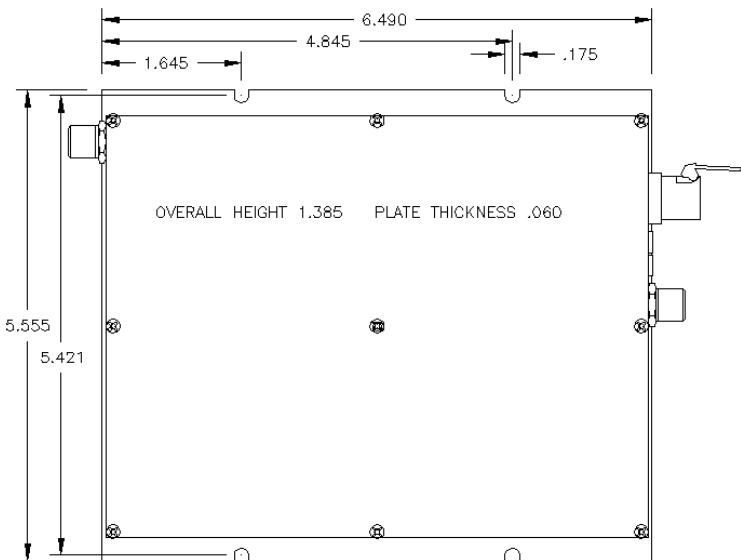

Figure 1 - OTOT-1000C-xx Mounting Diagram

OPTICAL CONNECTORS AND CLEANING

The standard optical connector is an SC/APC. In order to use FC/APC connectors, you must order a conversion kit, OTLL-SCFKIT. The standard optical connector location is on the opposite side from the RF connector. The connector can be moved to the other side by swapping it with a cover plate. Only a screwdriver is required for this operation. The fiber ends can be damaged by the insertion of contaminated connectors. Some types of customer damage to connectors are not covered under warranty. Fiber connectors should never be left uncovered. Pre-packaged alcohol wipes are the most convenient means of cleaning optical connectors. Clean alcohol and lint free wipes, such as Kim-Wipe type 34155, or swabs may also be used.

INTERNAL CONTROLS

There are no internal user adjustments. The only reason to open the unit would be to move the fiber connector to the other end of the unit. This should be done before the unit is attached to a rack mount kit. The unit should not be operated for long periods of time without a top cover. This can cause RF radiation and ingress problems. The internal cooling is also reduced when uncovered. Be sure to replace and tighten all top cover screws. Oscillation or RF radiation can be caused by loose or missing screws. There is no user adjustable internal laser power adjustment. Any change to the laser power will result in poorer modulation characteristics and reduced link performance.

EXTERNAL CONTROLS AND TEST POINTS

There are two external DC test points. One reads laser current at 1V per 50mA. A typical laser current of 30mA would read 0.6V at this test point. The laser power test point is 0.1V per mW. This is for historical tracking. The optical power meter is a much more accurate means of measuring power. Both of these test points should be measured with a high impedance voltmeter.

There is an external multi-turn RF input attenuation control on the front panel. This is set at the factory to the fully clockwise position which yields minimum attenuation. The user can add 4dB of attenuation with this control which allows the input RF level to be up to 4dB higher than the recommended levels. There is also an external 75Ω RF test point. This test point measures the laser drive level, not the RF input level. This test point has been adjusted to read a very specific level when the RF drive has been adjusted for optimum optical modulation. For the factory tested input loading of 77 analog and 42 digital channels, this test point should read +10dBmV at 547.25MHz with the RF gain control pot is fully clockwise. At this frequency, the loss in the connecting cable and any

impedance matching devices can be very significant. See the section on input loading for the proper test point levels with other input conditions.

INITIAL SETUP

Mount the unit and apply power. The laser is temperature controlled. The unit will operate immediately after turn on, but requires about 5 minutes to temperature stabilize. Measure and record the optical output with a power meter. Measure and record the laser current and optical power readings at the external test points. Measure and record the RF input levels. **CAUTION:** At this frequency range the loss and slope of coax cables is very significant. The best approach is to connect the cable that will go to the OTOT-1000C input directly to the measurement device. The input signals should be flat within ± 1 dB, preferably within ± 0.5 dB. Responses worse than this will result in reduced CNR and or distortion performance.

Special attention must be paid to the relative level of the channel that is used to set the RF gain and thus set the laser modulation. If this channel is much higher than the other channels, then setting the RF gain will cause the other channels to be lower than optimum, resulting in reduced CNR performance. If this channel is too low, then using it to set the RF gain will cause the other channels to be higher than optimum, resulting in reduced distortion performance. A 1dB to 2dB error will cause significantly impaired performance. Connect the RF input to the unit and adjust the RF gain control for a level that indicates proper modulation. For the factory test condition, this is +10dBmV at 547.25MHz. For other channel loadings, consult the next section. Do not forget to account for the loss in the connecting cable.

INPUT DRIVE vs. CHANNEL LOADING

The laser RF drive level is the primary determining factor of link distortion and CNR performance. The basic limitation on input drive is total input power. The following charts show the approximate input levels versus channel loading. The left axis shows the nominal RF input level. The unit will work with levels within ± 2 dB of this value. The right axis shows the test point reading for optimum modulation. Figure 2 is for the OTOT-1000C-3 and OTOT-1000C-6 models. Figure 3 is for all other optical power levels. Most systems run their digital channels at 6dB below the analog channels. This is a very convenient level for calculating loading. At 6dB down, simply divide the number of digital channels by 4 and add to the number of analog channels to get the total equivalent

analog channel loading. The factory test input is 77 analog channels with 42 digital channels at 6dB down. The number of equivalent analog channels is $77 + 42/4$, which equals 87.5. This is the 87.5 ch / +17.6dBmV input point on the graph. Some systems use an OMI meter to set laser modulation. The OTOT-1000C's have been individually adjusted for optimum performance. Setting all units for the same OMI, instead of using the test point, will result in reduced transmitter performance. If the channel loading is less than 40, you may decide not to increase the levels by the maximum possible amount. This will provide improved distortion at the cost of CNR. The best rule of thumb is to use the maximum possible levels for long haul links, and lower drive levels as the links get shorter.

REDUCING LINK GAIN

Short links can have reduced performance due to receiver overloading. Reducing the laser RF drive will cause reduced CNR performance. Attempting to lower the laser output power will have the even worse result of degrading both CNR and IMD. The correct solution is to lower the receiver input level with an optical attenuator such as the OTOA-1000. It is recommended that this be done at the receive location.

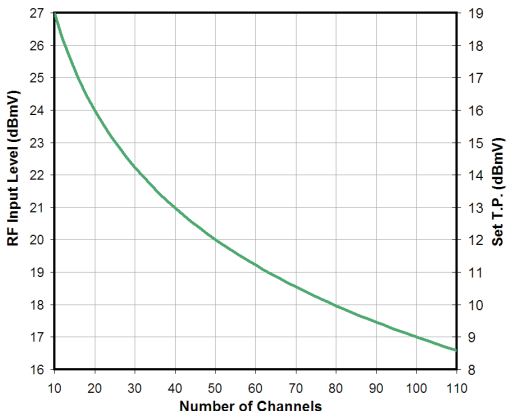

Figure 2 - Input Level vs. Channel Loading - Low-Power Units

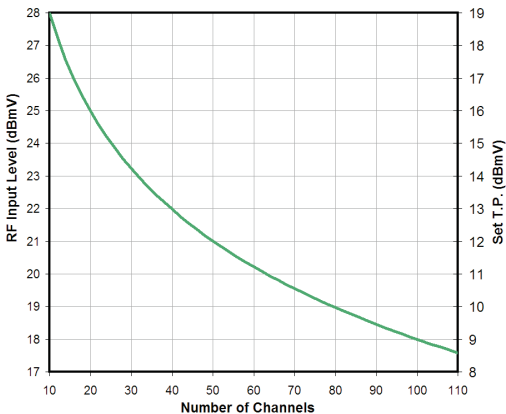

Figure 3 - Input Level vs. Channel Loading - High-Power Units

ACCESSORIES

| MODEL | DESCRIPTION |
|--------------|--|
| OTLL-SCFCKIT | Optical Connector Adapter Kit, SC/APC to FC/APC |
| OTLL-RMKIT-1 | Rack Mount Kit (Holds 3 OTOT-1000C's) |
| OTOA-1000 | Optical Fiber Attenuator, 1310nm, 1-7dB Variable Steps |
| OTLL-FANKIT | Replacement Fan Assembly |

RELATED OLSON TECHNOLOGY PRODUCTS

| MODEL | DESCRIPTION |
|----------------|---|
| OTPN-800C | Wideband (50-1,000MHz) Medium-Power Indoor Node |
| OTPN-2000C | Wideband (50-1,000MHz) High-Power Indoor Node |
| OTPN-2000C-PAL | Wideband (85-1,000MHz) High-Power Indoor Node |